

Product Identification

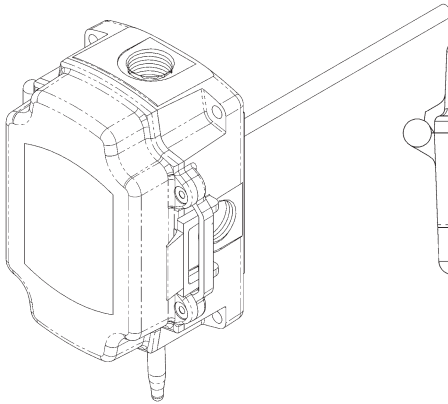

Fig. 1:
Non-Display ZPS in a
BAPI-Box with
Attached Static Tube

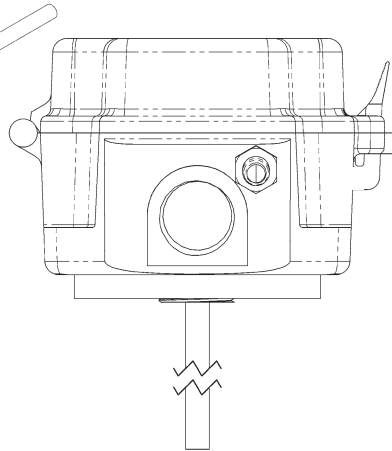

Fig. 2:
End view of ZPS in a
BAPI-Box with
Attached Static Tube

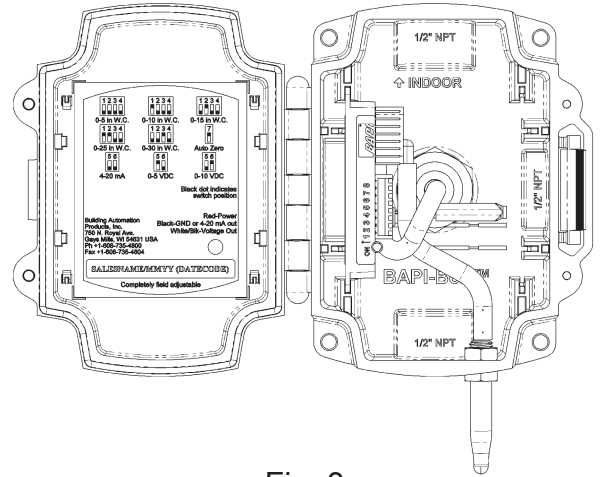

Fig. 3:
ZPS Display ZPS in a BAPI-Box
with Attached Static Tube
Cover Open

Mounting

Mount the unit to its mounting surface with four #10 screws through the holes in the mounting feet. The preferred mounting orientation is with the pressure ports facing down.

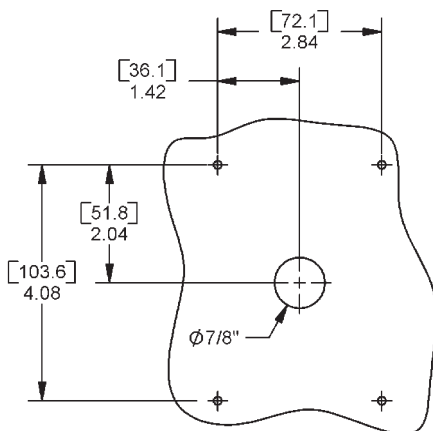

Figure 4: Mounting Hole Pattern
Note: BAPI recommends using #10 screws that require 5/32" pilot holes.

Note: Remove Blue Dust Covers from Pressure Ports Before Use

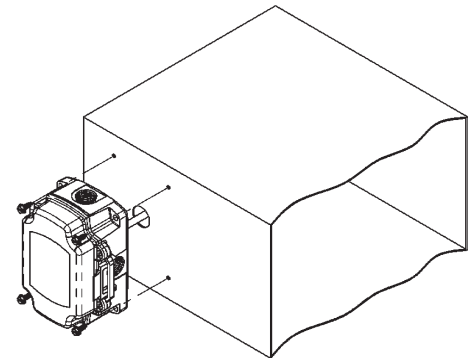
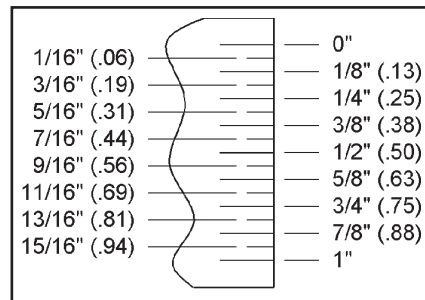

Figure 5:
Mounting to a duct

Tools & Material List

Screwdriver
Drill with 5/32" bit

#10 Screws
Wire

Sealant Filled Connectors

Specifications subject to change without notice.



Output Termination

Desired Output

4 to 20 mA
0 to 5 V or 0 to 10 V

Wire connections

Red (V+); Black (Return{ 4 to 20 mA Signal}); White (Not used)
Red (V+); Black (Ground); White (Output Voltage)

4 to 20 mA is "two wire" operation, the ZPS's red wire connects to a positive direct current voltage of 7 to 45 VDC, the ZPS's black wire becomes the return of the 4 to 20 mA signal and the ZPS's white wire, while unused, must be insulated from accidental contact with ground or any other potential. For 4 to 20 mA signaling only direct current can be used to power the ZPS.

0 to 5 V or 0 to 10 V is "three wire" operation, the ZPS's red wire connects to either 7 to 45 VDC or 7 to 32 VAC (0-5 VDC output) or 13 to 45 VDC or 13 to 32 VAC (0-10 VDC output), the ZPS's black wire is connected to ground and the ZPS's white wire is connected to an analog input of the controller. BAPI insulates the white wire in the factory before shipping to you, please remove the connector and strip the insulation from the white wire as desired.

To ensure that all wires are properly terminated, twist the stripped ends of each circuit together before inserting into the splice terminals. Gently tug on the wire after terminating to make sure of a good connection. If the wire comes out of the termination repeat the splice procedure.

Dip Switch Settings - Inches, Pascals, Display and No Display

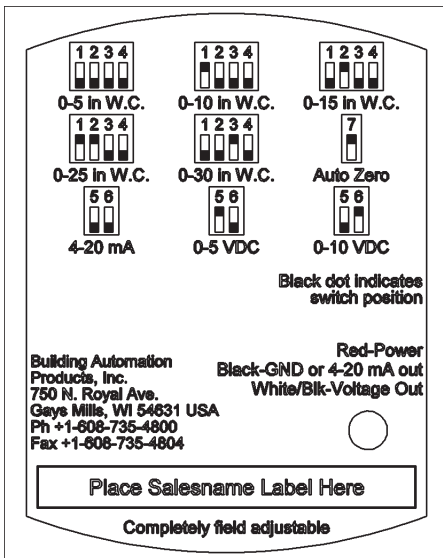

Figure 6:
DIP Switch Settings,
ZPS with No Display,
Inches W.C.

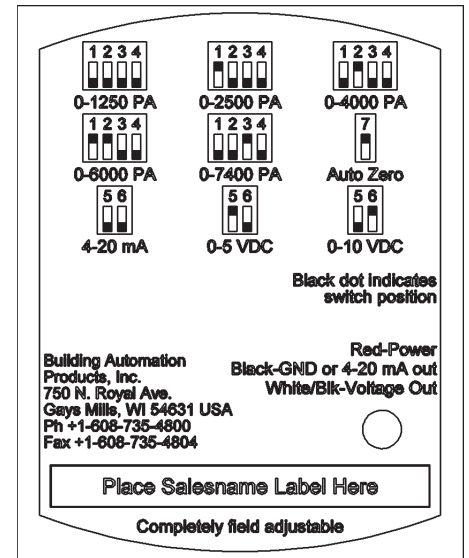

Figure 7:
DIP Switch Settings,
ZPS with No Display,
Pascals

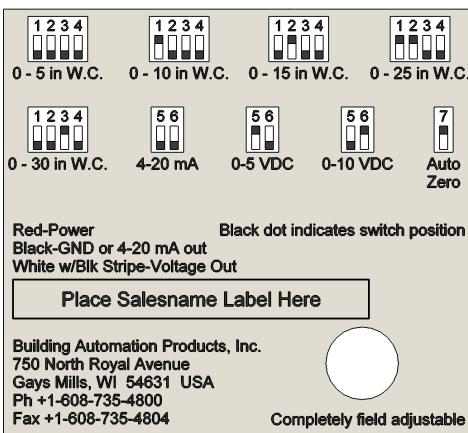

Figure 8:
DIP Switch Settings,
ZPS with Display,
Inches W.C.

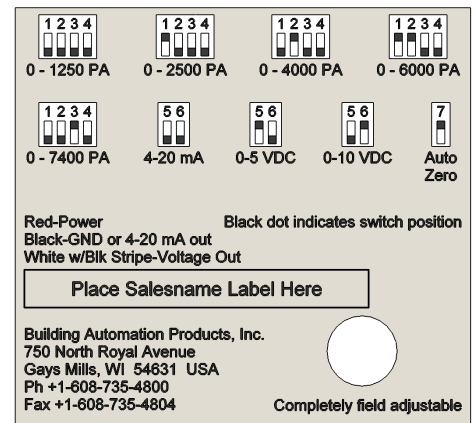

Figure 9:
DIP Switch Settings,
ZPS with Display,
Pascals

Specifications subject to change without notice.



Pressure Range Select

To adjust the pressure range, set dip switches 1-4 to the desired pressure range using the the label found inside the cover of the ZPS unit (or shown on this pg 2).

Note: If any of the switches are placed in an undefined combination the LED will fast blink and the output will be forced to 4mA or zero volts.

Output Range Select

To adjust the output range, set dip switches 5 & 6 to the desired output range using the the label found inside the cover of the ZPS unit (or shown on pg 2).

Note: If any of the switches are placed in an undefined combination the LED will fast blink and the output will be forced to 4mA or zero volts.

Auto-Zero Select

To auto zero the BAPI ZPS, remove the tubing from the pressure ports (to remove the normal pressure source). Make sure that the pressure ports are sheltered from any drafts, including the technician's breath. Ideally the two ports should be connected together with a short piece of tubing. Turning on switch 7 starts the auto-zero process. Switches 1 through 6 may be in any allowed configuration. The LED will blink at a fast rate and the output will be forced to zero (4mA or 0V) while the auto-zero is being performed. When the LED blinks at a slow rate, turn off switch 7 and reconnect the pressure source.

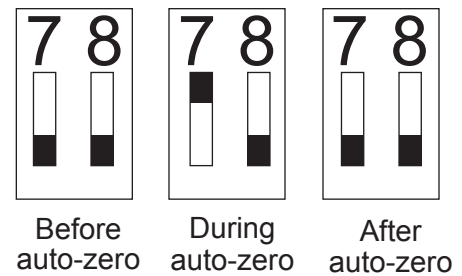
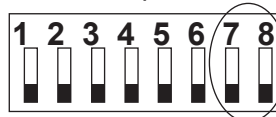

Fig. 10 Auto-Zero

Switch 8

Switch 8 is reserved for Factory use, leave in the off position.

Diagnostics

PROBLEMS:

LED does not light

LED is blinking fast
(1/2 second on, 1/2 second off)

Output stuck (high or low)

Output not tracking pressure properly

POSSIBLE SOLUTIONS:

- Check power connections for proper power

- The unit may be performing an auto-zero. Wait 10 seconds and check again.
- The dip switches are in an unsupported configuration, check the dip switch settings, both pressure and output, and change them to ranges desired

- Remove pressure from ports and perform auto-zero procedure

- Check dip switches for proper pressure range selection
- Check dip switches for proper output range selection

Switch 8

LED off	No Power
LED Blinking 1/2 sec on, 1/2 sec off	Auto-zero or dip switch in undefined configuration
LED on	Normal operation
LED Blinking 1/2 sec on, 4 sec off	Auto-zero complete

Specifications subject to change without notice.