

Parts Received

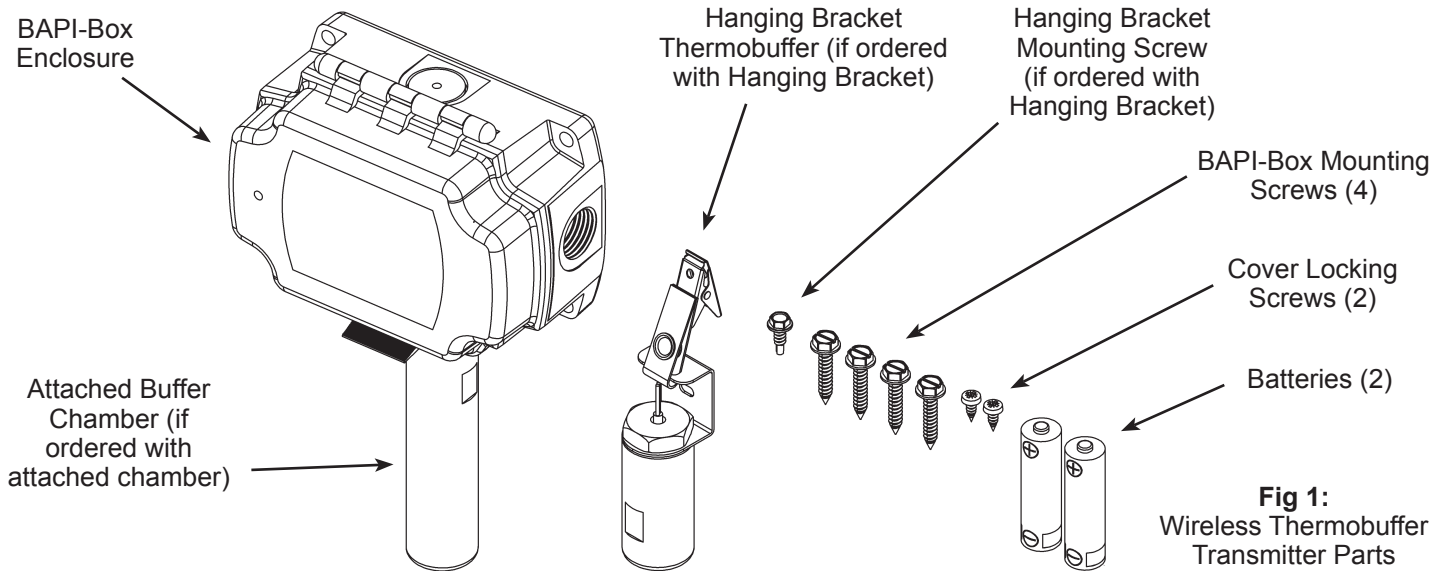

Mounting

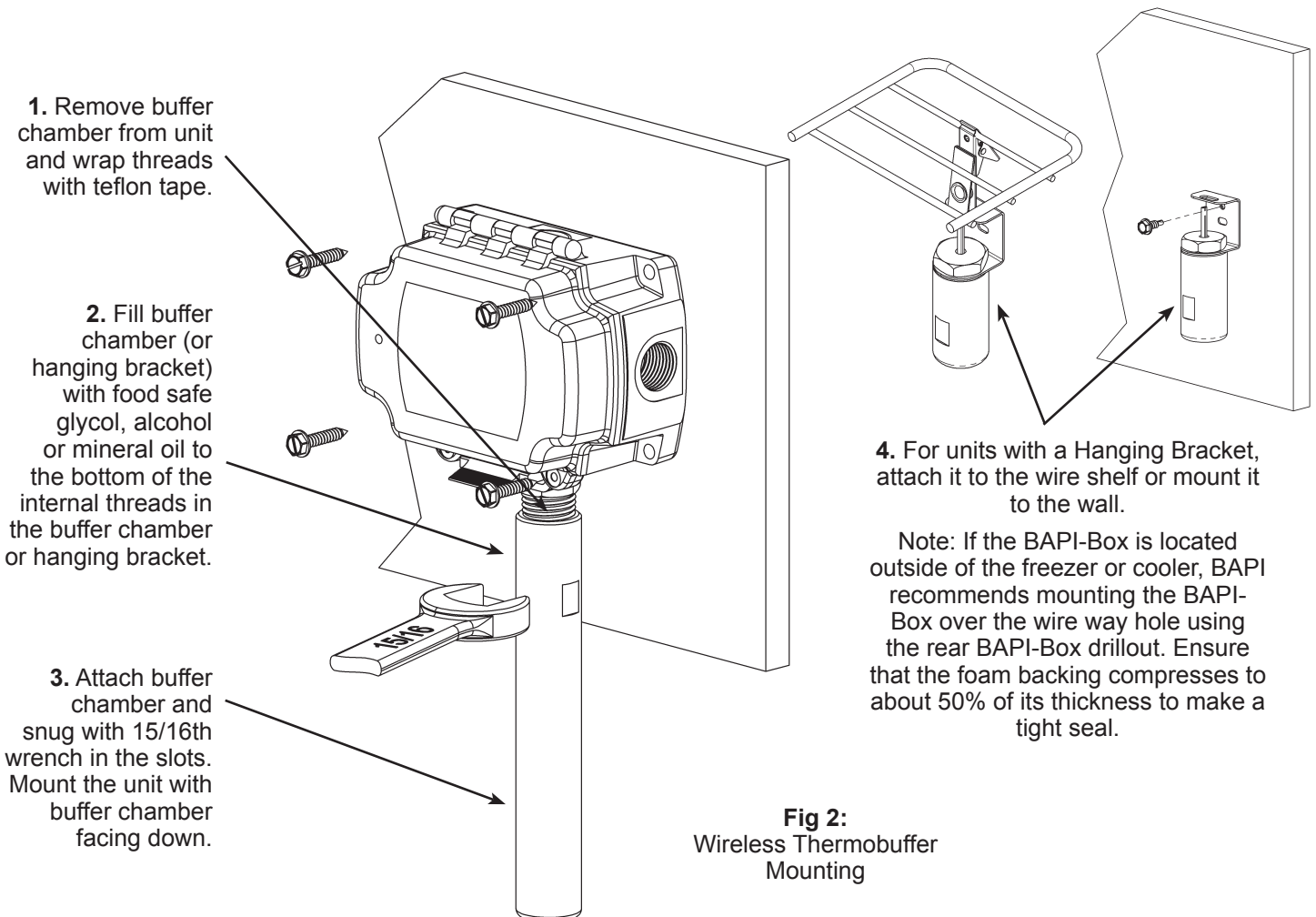

Specifications subject to change without notice.

Operation

Install the provided batteries or power the unit with 9 to 30 VDC (50 mA max) or 15 to 28 VAC (50 mA max). The unit will then begin transmitting.

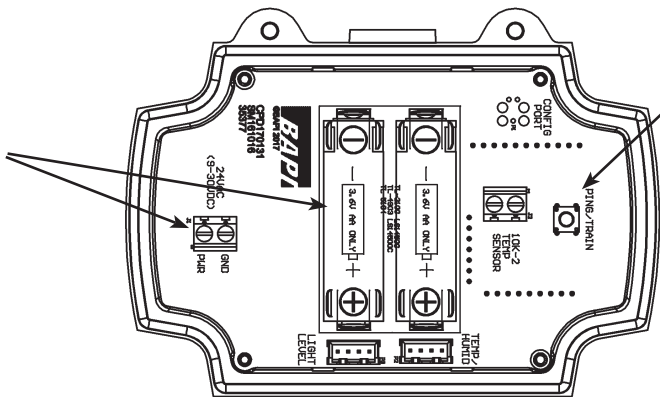

Pressing the "Ping/Train" button on the circuit board will force a transmission.

A green LED on the face of the unit flashes after each transmission.

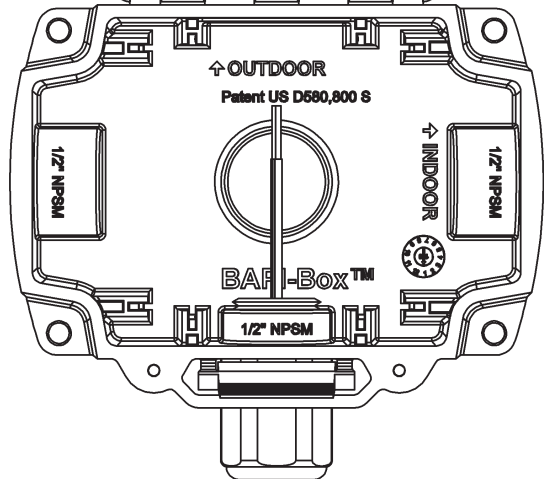
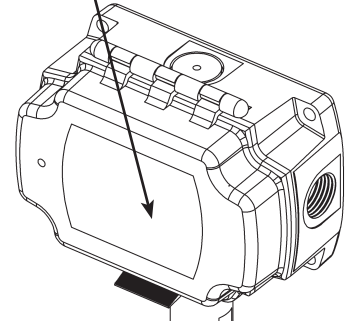

Note: The unit is factory set to transmit once every 5 minutes.

The transmission rate can be changed via the receiver/gateway network interface (as described in the gateway instruction sheet (39021_RCV_900_BACnet.pdf).

Fig 3:
Wireless Transmitter Internal Components (1" Hanging Bracket Unit shown)

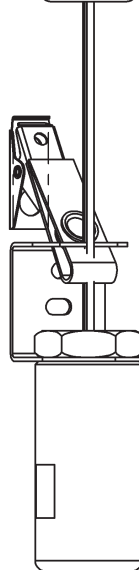

Specifications subject to change without notice.



Wireless Sensor Reset

Pressing the “Ping/Training” button on a wireless sensor for 15 seconds will reset the sensor to the original factory default settings (which are accessed through the associated Gateway receiver). This reset procedure can be used to re-establish communication between the sensor and the Gateway if communication is lost due to mismatched addresses. The address of the sensor will be reset to the default: 42415049. This default address can then be entered for the Gateway (as described in the Gateway instructions document “39021_RCV_900_BACnet.pdf”) to re-establish communication with the sensor. Once communication is established, the address of the Gateway and the sensor can be returned to the previous address to re-establish communication with the other sensors on the network (as described in the Gateway instructions document “39021_RCV_900_BACnet.pdf”).

Besides resetting the wireless address, the reset procedure will also return the sensor to these default values:

- Channel = 1, 3
- Transmit power = 0 dBm
- Reported intervals = 300 seconds
- Sample Interval = 300 seconds
- AES key = not affected by the reset procedure
- Battery warning Voltage = 2.5
- All offsets = 0

Diagnostics

Possible Problems:

Temperature reading is incorrect.

Possible Solutions:

Verify that the controller’s software is configured properly.

Make sure the transmitters are within range of the receiver/gateway.

Verify that the green LED visible on the face of the unit flashes when the “Ping/Train” button on the circuit board is pressed, indicating a transmission. If the LED does not flash, replace the batteries.

Verify proper power and termination of the receiver/gateway as shown in the receiver/gateway instructions (39021_RCV_900_BACnet.pdf) available on the BAPI website.

Check that the receiver/gateway’s yellow LED to the left of the Ethernet cable jack is illuminated and that the green LED to the right is blinking indicating a good Ethernet network connection and network activity.

Sensor is not communicating with the Gateway

Perform the “Wireless Sensor Reset” procedure as described above and in the Gateway instructions document “39021_RCV_900_BACnet.pdf” available on the BAPI website or by contacting BAPI.

FCC Wireless Certification and Interference Statement

Wireless BAPI-Box Transmitter (WBB900) - FCC ID: T4FWBB900

This equipment has been tested and found to comply with the limits for a class B digital device, pursuant to part 15 of the FCC Rules. These limits are designed to provide reasonable protection against harmful interference in a residential installation. This equipment generates, uses, and can radiate radio frequency energy, and if not installed and used in accordance with the instructions, may cause harmful interference to radio communications. However, there is no guarantee that interference will not occur in a particular installation. If this equipment does cause harmful interference to radio or television reception, which can be determined by turning the equipment off and on, the user is encouraged to try to correct the interference by one or more of the following measures:

- Reorient or relocate the receiving antenna.
- Increase the separation between the equipment and receiver.
- Connect the equipment into an outlet on a circuit different from that to which the receiver is connected.
- Consult the dealer or an experienced radio / TV technician for help.

In order to maintain compliance with FCC regulations, shielded cables must be used with this equipment. Operation with non-approved equipment or unshielded cables is likely to result in interference to radio and TV reception. The user is cautioned that changes and modifications made to the equipment without the approval of the manufacturer could void the user’s authority to operate this equipment.

Specifications subject to change without notice.